

The Intelligent PDM Vault from SolidWorks



real inspiration

SUMMARY

Product data management systems perform a variety of tasks to help collaborate, control, connect, and communicate information throughout an engineering organization. Getting the most out of your PDM efforts starts with the Intelligent PDM Vault from SolidWorks.



The Intelligent PDM Vault features seven significant improvements beyond a simple hierarchy of stored files.

Business as usual

You store your design and manufacturing data on a network drive for all to use, right? Because you're savvy about the need for an administrator to control access while offering the rest of the staff ease of use, you've taken a centralized approach and put completed projects on the network such as F:\Released. This approach is similar to storing files in a locked file cabinet: they're pretty safe, they're not scattered on multiple local hard drives, and they can be regularly backed up by the information technology (IT) department on a tape or optical disk drive.

Plus, you recognize that instead of being static, many of these files are either occasionally updated or reused for new projects. With that in mind, you've structured a standard workflow where users can pull out a file and work on it while the file is assigned to a temporary directory such as F:\In-Progress. The administrator assigns different network operating system rights to each directory, such as read-only; signs off the reworked files for transfer; and makes sure it gets back in the file folder labeled F:\Released.



However, this type of manual check-in/check-out system is prone to errors in its daily operation; the wrong version is opened, someone works on a copy without tracking revisions, or a coworker renames it – all errors that can cost you time and accuracy. To minimize these errors, you need a structured product data management (PDM) system. And to truly improve the efficiency of your managed design process, you need the benefits of the SolidWorks® Intelligent PDM Vault included with SolidWorks Enterprise PDM.

As with the “locked cabinet” containing the folder F:\Released, a vault also stores files in a centralized location. But just as a 3D CAD model offers a wealth of information beyond that found on a flat paper drawing, the Intelligent PDM Vault features seven significant improvements beyond a simple hierarchy of stored files. That way, engineers and designers can focus on design rather than administrative tasks.

Seven steps to intelligent PDM

1 – Intelligent data relationship knowledge

The first difference you'll notice with the Intelligent PDM Vault is that it understands the relationship among parts, drawings, and assemblies. By simply dragging, copying, or importing CAD files into the Vault, valuable information such as Where Used and Contains can be automatically retrieved at the touch of a button. If you search for a part, the Vault tells you which assemblies use it; and if you look at an assembly, the Vault automatically knows all the parts that are in it, **even if they are renamed or moved.**

The Intelligent PDM Vault understands the relationship among parts, drawings, and assemblies.

2 – Controlled check-out

To access a file, you must check it out from the Vault, similar to checking a book out of the library. This is a simple process of using the right mouse button and selecting Check Out. The Intelligent PDM Vault automatically locks the file with your name on it, so other users can view the file but not make changes to it at the same time. The Vault also keeps a full history that stores all operations performed on each file, so you always know who has worked on which part, assembly, and project.

3 – Globally known check-out status

While a file is in use, its status (state, user, check-out date) is available for all to see. This allows everyone on the team to know who is working on which files and thus avoid redundant work.

4 – Absolute overwrite protection

The Vault ensures that another person can't overwrite the changes that someone else is in the process of making. A complete Revision history is maintained automatically with a detailed log showing each and every minor *version* and major *revision* that have been made to each file in the vault. This feature helps to ensure that projects meet compliance and audit requirements, and that field service can bring up the correct print revision at any customer location.

5 – Controlled check-in

When a user has completed changes to a file, there is a simple but structured process for checking a file back into the Vault; again, this is as simple as making a right mouse button click and then selecting Check-in. This enables the team to see your latest changes, while allowing another user to immediately check out their worked file.

6 – Intelligent version/history branching

If you work on a design for a month, checking it in and out during each of the four weeks, the Intelligent PDM Vault acknowledges and tracks the generation of four *versions*. At any time, you can decide that you don't like how the design has evolved in say, version 4, and go back and start again with version 3, 2, or 1. Since the tracking is done automatically, without the user saving multiple versions under slightly different file names, this facilitates better and more innovative designs.

7 – Simplified revision nomenclature

Traditional filing systems exert no control over the naming and renaming of files. As a result, they often acquire long and complicated names to reflect the features of the particular revision. Within the Intelligent PDM Vault, file naming can be automatic when you are satisfied with your latest version. All *revision* information (author, current status, and additional data) is included as part of the information in the Vault, but it does *not* have to be included in the actual file or folder names. Part, drawing, and assembly numbers can be automatically created by simply using a convenient serial numbering system.

The Intelligent PDM Vault keeps a full history that stores all operations performed on each file, so you always know who has worked on which part, assembly, and project.

The Intelligent PDM Vault at work

When you open the Vault from the SolidWorks menu, a simple six-tab window presents the choices of Preview, Data Card, Version, Bill of Materials, Contains, and Where Used. Each tab takes you to a wealth of possibilities for interacting not only with SolidWorks drawing and assembly files, but also with corresponding files in other CAD systems (such as AutoCAD® and ProE®), as well as Microsoft® Word, Excel, eDrawings® files, and dozens of other standard formats – all controllable within the Vault functions.

Preview

The Preview tab allows all users to see parts, drawings, assemblies, graphic files, office documents, and videos without opening up another application. Within 3D model previews, you can rotate, pan, and zoom to get a better view of the design – all without ever opening SolidWorks.

With the Intelligent PDM Vault, you can quickly see which version you are working on and how many total versions there are.

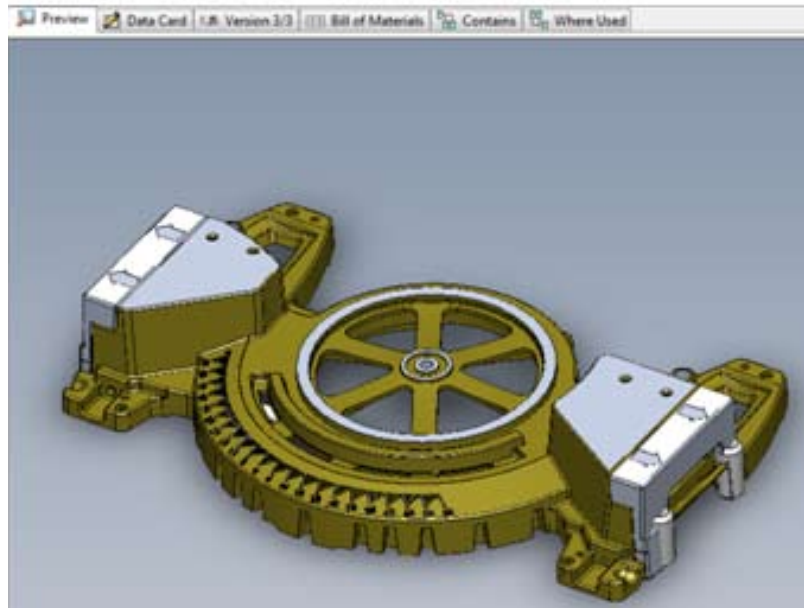

Data Card

The Data Card tab is where information is stored about each file. For example, a part may have information regarding the Vendor and Project Name, Description, Part Number, Cost, and Weight. Since this data is all searchable, you can find a part in many ways.

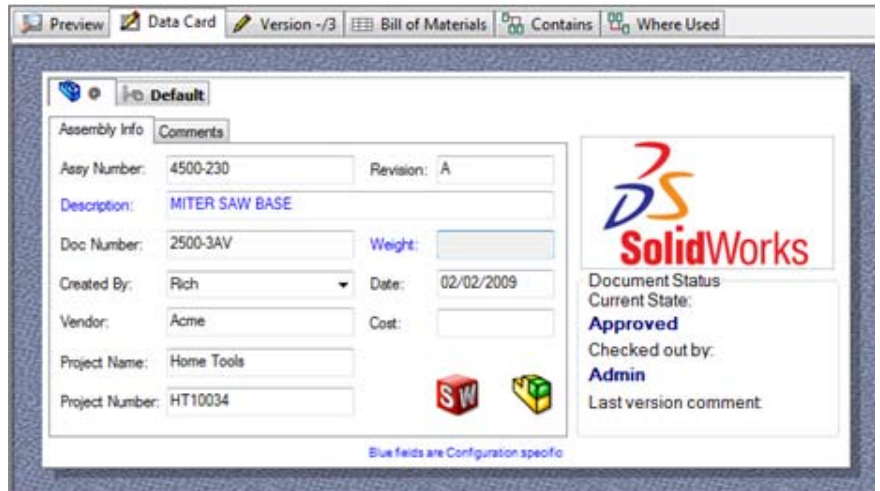

Version

Each time you open a file and save changes, that file becomes another version. The Version tab lets you quickly see which version you are working on and how many total versions there are. You can also quickly see if the file is waiting for approval.

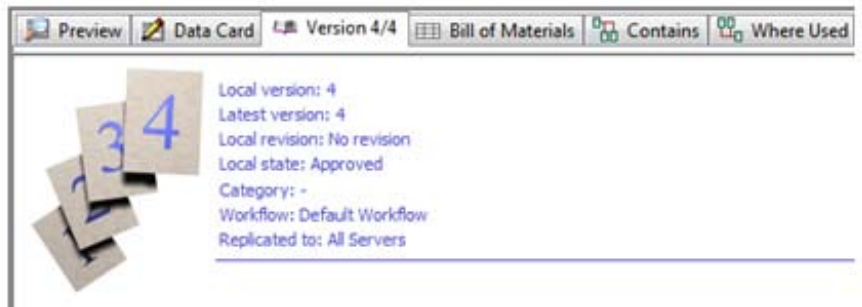

Bill of Materials

With the Intelligent PDM Vault, you can view all of the parts in an assembly without launching the CAD system.

In addition to viewing the parts that comprise an assembly, you can view multiple bill of material (BOM) types within the Intelligent PDM Vault system. The Vault automatically creates a BOM by evaluating the structure of the assembly; it understands the relationships between parts and assemblies, and is able to extract that information as a bill of material. If parts are added or deleted from the assembly, the BOM will automatically update, all still in the Intelligent PDM Vault system. You can also choose the data display format, showing different column information that is relevant for various departments and users. The BOM can be edited to account for make-versus-buy decisions and to add non-modeled items, such as glue, paint, assembly instructions, and tooling. A finalized BOM can be routed throughout the organization for approvals.

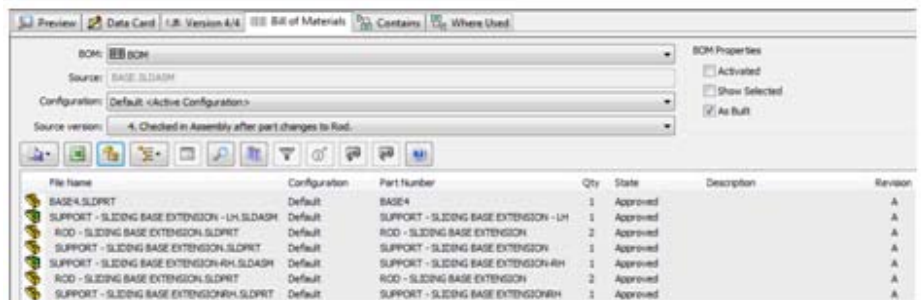

The Intelligent PDM Vault can also read any customized drawing and assembly BOM created in SolidWorks and obey all CAD rules, such as excluding items from the BOM and listing internal components. These drawing and assembly BOM lists can also be edited and routed throughout the company outside of SolidWorks software, without the need to print or access the CAD system.

Contains

Assemblies contain multiple parts. To get a complete listing of all the parts within an assembly, you would generally open the assembly in your CAD system and create a bill of materials. With the Intelligent PDM Vault, however, you can view all of the parts without launching the CAD system by simply selecting the Contains tab. This allows both CAD users, such as engineers and designers, as well as non-CAD users in purchasing, sales, marketing, and manufacturing to view parts lists by simply viewing the Vault.

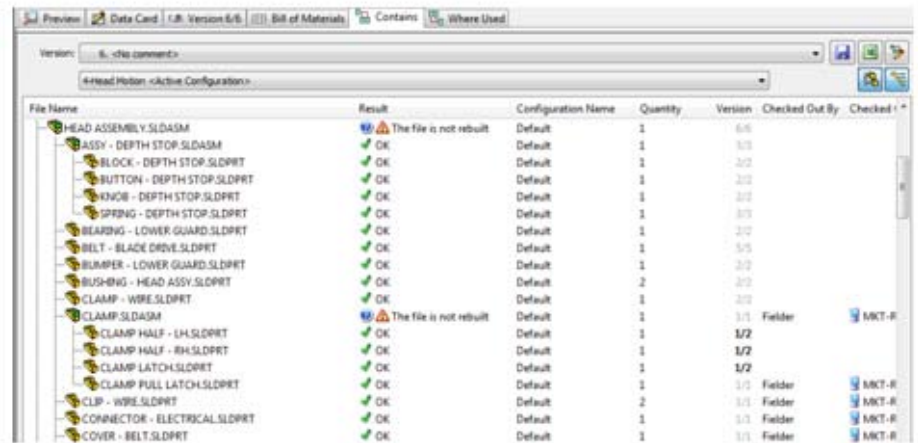

When files are renamed with the Intelligent PDM Vault, all references and associations are automatically updated and maintained.

Where Used

Since parts can typically be used in multiple assemblies, a change to one part may affect any or all of those assemblies. When an engineering change order is accomplished on such a part, regular PDM systems can take hours to find all the possibly affected assemblies. With the Intelligent PDM Vault, however, all relationships are automatically understood and maintained – the user simply selects a part in the Vault and immediately sees a list of every assembly that utilizes that part. A single click of the mouse then brings up any associated drawings, specifications, pictures, quotes, letters, and compliance documents.

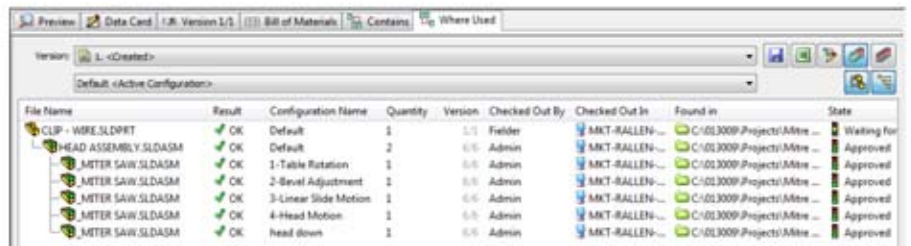

... And a few more useful vault features

Automatic tracking of renamed files

When files are renamed with a traditional file control system, assemblies have a difficult time finding all the references to that assembly. But when files are renamed with the Intelligent PDM Vault, all references and associations are automatically updated and maintained. Even files that lack proper names or that didn't have part numbers initially assigned to them can be changed one or more times, without spending hours rebuilding the assemblies. All renaming and linking are automatically updated in the Vault.

Assembly links maintained when moving files

Sometimes files are moved from folder to folder to reorganize information. As parts are replaced or new projects are started, you may want to move a part from one project folder to another. When files are moved within the Intelligent PDM Vault – no matter where the file is located – all assemblies and relationships are automatically updated and maintained, and no assembly links are broken. Again, this feature saves users a significant amount of time and energy.

By reducing administrative time in managing and accessing files, the Intelligent PDM Vault keeps engineers and designers focused on their primary task – creating better products.



AUTOMATED WORKFLOW WITH STATE-TO-STATE TRANSITIONS

Rather than physically move files from one directory to another, an Intelligent PDM Vault allows files to be moved from *state* to *state*, such as F:\In-Progress to F:\Released, by simply selecting a menu choice to send files through two or more steps, referred to as transitions. This option eliminates the need for users or administrators to copy or move files on a network server. Multiple files can be automatically moved through processes that gain approvals of multiple people within the organization and that collect electronic signatures while protecting the files from unauthorized access. Typical processes include new product development and engineering change orders.

Moving forward with the Intelligent PDM Vault

Product data management systems perform a variety of tasks to help collaborate, control, connect, and communicate information throughout an engineering organization. Getting the most out of your PDM efforts starts with the Intelligent PDM Vault. You can reduce errors, help find and manage files, and simplify administrative loads. In addition, you can rename or move files with no adverse effect on existing relationships, and keep them secure and safe in the Vault, where information such as Contains and Where Used is easily retrievable.

By reducing administrative time in managing and accessing files, the Intelligent PDM Vault keeps engineers and designers focused on their primary task – creating better products.

scalability

secured access

remote access

scalability

remote access

approval

automated

approval

document

document

preview

reuse

design

data

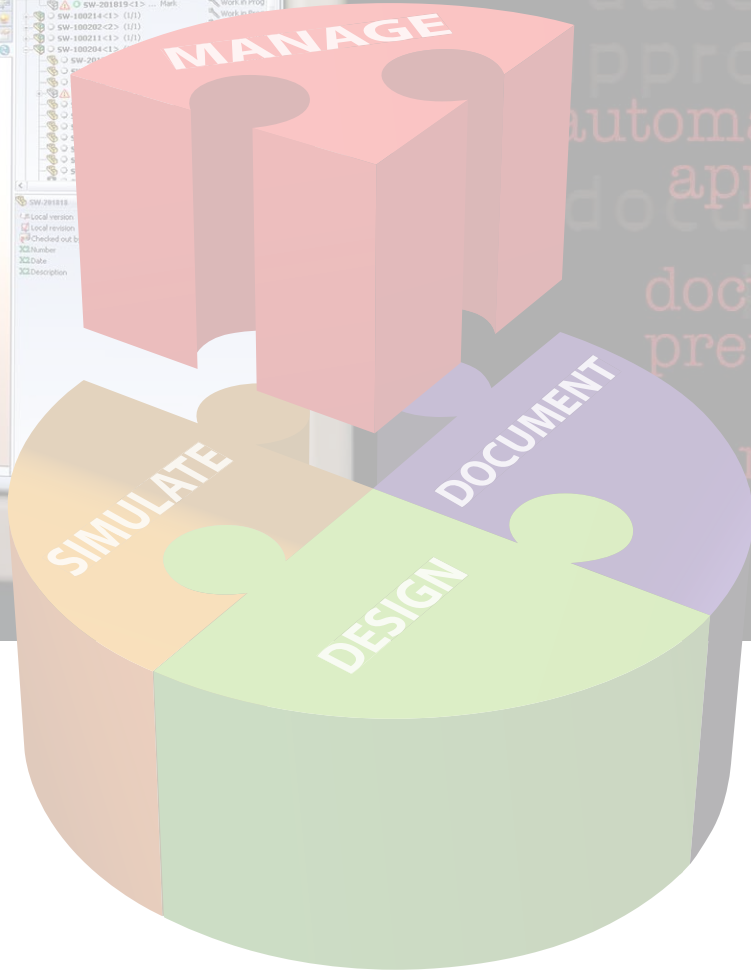
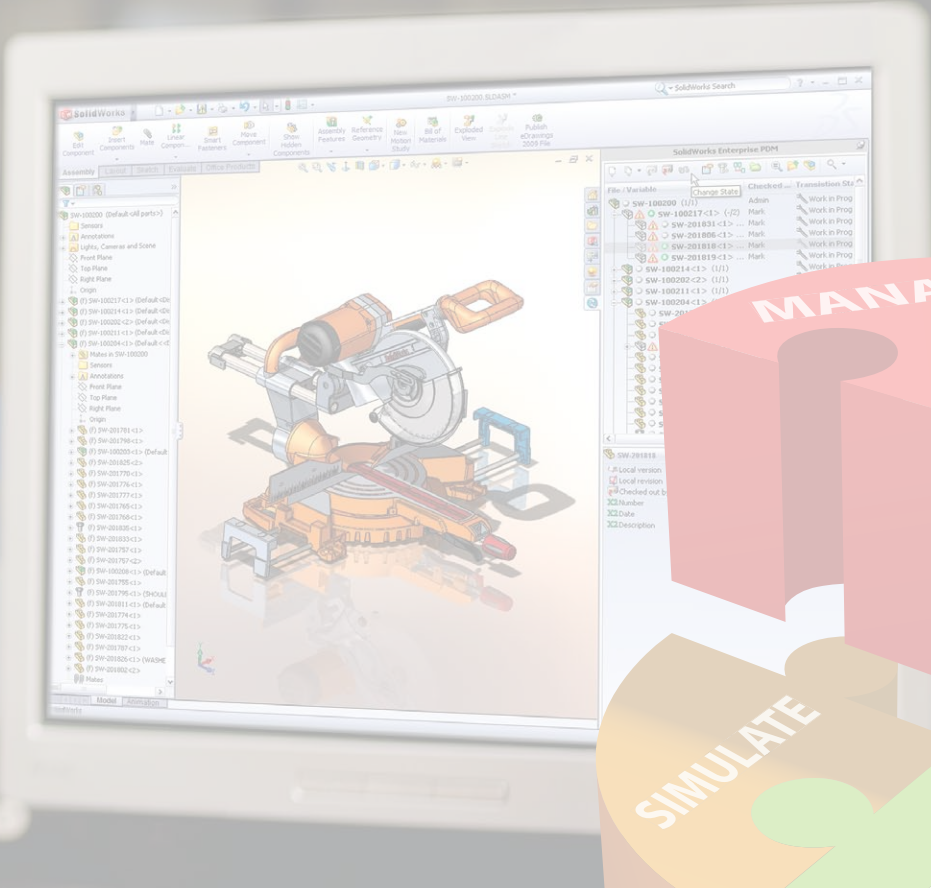

Dassault Systèmes SolidWorks Corp.
 300 Baker Avenue
 Concord, MA 01742 USA
 Phone: 1 800 693 9000
 Outside the US: +1 978 371 5011
 Email: info@solidworks.com
 www.solidworks.com

www.solidworks.com